

ANNEX I
SUMMARY OF PRODUCT CHARACTERISTICS

1. NAME OF THE MEDICINAL PRODUCT

Ovitrelle 250 micrograms/0.5 mL solution for injection in pre-filled syringe

2. QUALITATIVE AND QUANTITATIVE COMPOSITION

Each pre-filled syringe contains 250 micrograms choriogonadotropin alfa* (equivalent to approximately 6,500 IU) in 0.5 mL solution.

* recombinant human chorionic gonadotropin, r-hCG produced in Chinese hamster ovary (CHO) cells by recombinant DNA technology

For the full list of excipients, see section 6.1.

3. PHARMACEUTICAL FORM

Solution for injection in pre-filled syringe.

Clear, colourless to slightly yellow solution.

The pH of the solution is 7.0 ± 0.3 , its osmolality 250-400 mOsm/kg.

4. CLINICAL PARTICULARS

4.1 Therapeutic indications

Ovitrelle is indicated in the treatment of

- Adult women undergoing superovulation prior to assisted reproductive technologies (ART) such as *in vitro* fertilisation (IVF): Ovitrelle is administered to trigger final follicular maturation and luteinisation after stimulation of follicular growth,
- Anovulatory or oligo-ovulatory adult women: Ovitrelle is administered to trigger ovulation and luteinisation in anovulatory or oligo-ovulatory women after stimulation of follicular growth.

4.2 Posology and method of administration

Treatment with Ovitrelle should be performed under the supervision of a physician experienced in the treatment of fertility problems.

Posology

The maximum dose is 250 micrograms. The following dose regimen should be used:

- Women undergoing superovulation prior to assisted reproductive technologies (ART) such as *in vitro* fertilisation (IVF):

One pre-filled syringe of Ovitrelle (250 micrograms) is administered 24 to 48 hours after the last administration of a follicle stimulating hormone (FSH) or human menopausal gonadotropin (hMG) preparation, i.e. when optimal stimulation of follicular growth is achieved.

- Anovulatory or oligo-ovulatory women:

One pre-filled syringe of Ovitrelle (250 micrograms) is administered 24 to 48 hours after optimal stimulation of follicular growth is achieved. The patient is recommended to have coitus on the day of, and the day after, Ovitrelle injection.

Special populations

Renal or hepatic impairment

Safety, efficacy and pharmacokinetics of Ovitrelle in patients with renal or hepatic impairment have not been established.

Paediatric population

There is no relevant use of Ovitrelle in the paediatric population.

Method of administration

For subcutaneous use. Self-administration of Ovitrelle should only be performed by patients who are adequately trained and have access to expert advice.

Ovitrelle is for single use only.

4.3 Contraindications

- Hypersensitivity to the active substance or to any of the excipients listed in section 6.1
- Tumours of the hypothalamus or pituitary gland
- Ovarian enlargement or cyst unrelated to polycystic ovarian syndrome
- Gynaecological haemorrhages of unknown aetiology
- Ovarian, uterine or mammary carcinoma
- Active thromboembolic disorders

Ovitrelle must not be used in conditions when an effective response cannot be obtained, such as

- primary ovarian failure
- malformations of sexual organs incompatible with pregnancy
- fibroid tumours of the uterus incompatible with pregnancy
- postmenopausal women

4.4 Special warnings and precautions for use

Traceability

In order to improve the traceability of biological medicinal products, the name and the batch number of the administered product should be clearly recorded.

General recommendations

Before starting treatment, the couple's infertility should be assessed as appropriate and putative contraindications for pregnancy evaluated. In particular, patients should be evaluated for hypothyroidism, adrenocortical deficiency, hyperprolactinemia and pituitary or hypothalamic tumours, and appropriate specific treatment given.

There is no clinical experience with Ovitrelle in the treatment of other conditions (such as corpus luteum insufficiency or male conditions); therefore, Ovitrelle is not indicated in these conditions.

Ovarian hyperstimulation syndrome (OHSS)

A certain degree of ovarian enlargement is an expected effect of controlled ovarian stimulation. It is more commonly seen in women with polycystic ovarian syndrome and usually regresses without treatment.

In distinction to uncomplicated ovarian enlargement, OHSS is a condition that can manifest itself with increasing degrees of severity. It comprises marked ovarian enlargement, high serum sex steroids, and an increase in vascular permeability which can result in an accumulation of fluid in the peritoneal, pleural and, rarely, in the pericardial cavities.

Mild manifestations of OHSS may include abdominal pain, abdominal discomfort and distension, and enlarged ovaries. Moderate OHSS may additionally present with nausea, vomiting, ultrasound evidence of ascites and marked ovarian enlargement.

Severe OHSS further includes symptoms such as severe ovarian enlargement, weight gain, dyspnoea or oliguria. Clinical evaluation may reveal signs such as hypovolaemia, haemoconcentration, electrolyte imbalances, ascites, pleural effusions, or acute pulmonary distress. Very rarely, severe OHSS may be complicated by ovarian torsion or thromboembolic events, such as pulmonary embolism, ischaemic stroke or myocardial infarction.

Independent risk factors for developing OHSS include young age, lean body mass, polycystic ovarian syndrome, higher doses of exogenous gonadotropins, high absolute or rapidly rising serum estradiol levels and previous episodes of OHSS, large number of developing ovarian follicles and large number of oocytes retrieved in ART cycles.

Adherence to recommended Ovitrelle dosage and regimen of administration can minimise the risk of ovarian hyperstimulation. Monitoring of stimulation cycles by ultrasound scans as well as estradiol measurements are recommended to early identify risk factors.

There is evidence to suggest that hCG plays a key role in triggering OHSS and that the syndrome may be more severe and more protracted if pregnancy occurs. Therefore, if signs of ovarian hyperstimulation occur, it is recommended that hCG be withheld and the patient be advised to refrain from coitus or use barrier contraceptive methods for at least 4 days.

As OHSS may progress rapidly (within 24 hours) or over several days to become a serious medical event, patients should be followed for at least two weeks after hCG administration.

Mild or moderate OHSS usually resolves spontaneously. If severe OHSS occurs, it is recommended that gonadotropin treatment be stopped and that the patient be hospitalised and appropriate therapy be started.

Multiple pregnancy

In patients undergoing induction of ovulation, the incidence of multiple pregnancy and births is increased compared with natural conception. The majority of multiple conceptions are twins. Multiple pregnancies, especially high order, carry an increased risk of adverse maternal and perinatal outcomes.

To minimise the risk of higher order multiple pregnancy, careful monitoring of ovarian response is recommended. In patients undergoing ART procedures the risk of multiple pregnancy is related mainly to the number of embryos replaced, their quality and the patient age.

Pregnancy loss

The incidence of pregnancy loss by miscarriage or abortion is higher in patients undergoing stimulation of follicular growth for ovulation induction or ART than following natural conception.

Ectopic pregnancy

Women with a history of tubal disease are at increased risk for ectopic pregnancy, whether the pregnancy is obtained by spontaneous conception or with fertility treatments. The prevalence of ectopic pregnancy after ART in this population was reported to be higher than in the general population.

Congenital malformations

The prevalence of congenital malformations after ART may be slightly higher than after spontaneous conceptions. This is thought to be due to differences in parental characteristics (e.g. maternal age, sperm characteristics) and the higher incidence of multiple pregnancies.

Thromboembolic events

In women with recent thromboembolic disease or women with generally recognised risk factors for thromboembolic events, such as personal or family history, treatment with gonadotropins may further increase the risk for aggravation or occurrence of such events. In these women, the benefits of gonadotropin administration need to be weighed against the risks. It should be noted, however, that pregnancy itself as well as OHSS also carry an increased risk of thromboembolic events.

Reproductive system neoplasms

There have been reports of ovarian and other reproductive system neoplasms, both benign and malignant, in women who have undergone multiple treatment regimens for infertility. It is not yet established whether or not treatment with gonadotropins increases the risk of these tumours in infertile women.

Interference with serum or urinary testing

Following administration, Ovitrelle may interfere for up to ten days with the immunological determination of serum or urinary hCG, potentially leading to a false positive pregnancy test. Patients should be made aware of this.

Sodium content

This medicinal product contains less than 1 mmol sodium (23 mg) per dose, i.e. it is essentially “sodium-free”.

4.5 Interaction with other medicinal products and other forms of interaction

No specific interaction studies with Ovitrelle and other medicinal products have been performed; however, no clinically significant medicinal product interactions have been reported during hCG therapy.

4.6 Fertility, pregnancy and lactation

Pregnancy

There is no indication for the use of Ovitrelle during pregnancy. Data on a limited number of exposed pregnancies indicate no increased risks of malformation or foeto/neonatal toxicity. No reproduction studies with choriogonadotropin alfa in animals were performed (see section 5.3). The potential risk for humans is unknown.

Breast-feeding

Ovitrelle is not indicated during breastfeeding. There are no data on the excretion of choriogonadotropin alfa in milk.

Fertility

Ovitrelle is indicated for use in infertility (see section 4.1).

4.7 Effects on ability to drive and use machines

Ovitrelle has no or negligible influence on the ability to drive and use machines.

4.8 Undesirable effects

Summary of the safety profile

In comparative trials with different doses of Ovitrelle, OHSS was found to be associated with Ovitrelle in a dose-related fashion. OHSS was observed in approximately 4% of patients treated with Ovitrelle. Severe OHSS was reported in less than 0.5% of patients (see section 4.4).

List of adverse reactions

The following definitions apply to the frequency terminology used hereafter: very common ($\geq 1/10$), common ($\geq 1/100$ to $< 1/10$), uncommon ($\geq 1/1,000$ to $< 1/100$), rare ($\geq 1/10,000$ to $< 1/1,000$), very rare ($< 1/10,000$), not known (cannot be estimated from the available data).

Immune system disorders

Very rare: Mild to severe hypersensitivity reactions including rash, anaphylactic reactions and shock

Nervous system disorders

Common: Headache

Vascular disorders

Very rare: Thromboembolism (both in association with and separate from OHSS)

Gastrointestinal disorders

Common: Abdominal pain, abdominal distension, nausea, vomiting

Uncommon: Abdominal discomfort, diarrhoea

Reproductive system and breast disorders

Common: Mild or moderate OHSS

Uncommon: Severe OHSS

General disorders and administration site conditions

Common: Injection site reactions.

Reporting of suspected adverse reactions

Reporting suspected adverse reactions after authorisation of the medicinal product is important. It allows continued monitoring of the benefit/risk balance of the medicinal product. Healthcare professionals are asked to report any suspected adverse reactions via the national reporting system listed in [Appendix V](#).

4.9 Overdose

The effects of an overdose of Ovitrelle are unknown. Nevertheless, there is a possibility that OHSS may result from an overdose of Ovitrelle (see section 4.4).

5. PHARMACOLOGICAL PROPERTIES

5.1 Pharmacodynamic properties

Pharmacotherapeutic group: Sex hormones and modulators of the genital system, gonadotropins, ATC code: G03GA08

Mechanism of action

Ovitrelle is a medicinal product of choriogonadotropin alfa produced by recombinant DNA techniques. It shares the amino acid sequence with urinary hCG. Chorionic gonadotropin binds on the ovarian theca (and granulosa) cells to a transmembrane receptor shared with the luteinising hormone, the LH/CG receptor.

Pharmacodynamic effects

The principal pharmacodynamic activity in women is oocyte meiosis resumption, follicular rupture (ovulation), corpus luteum formation and production of progesterone and estradiol by the corpus luteum.

In women, chorionic gonadotropin acts as a surrogate luteinising hormone surge that triggers ovulation.

Ovitrelle is used to trigger final follicular maturation and early luteinisation after use of medicinal products for stimulation of follicular growth.

Clinical efficacy and safety

In comparative clinical trials, administration of a dose of 250 micrograms of Ovitrelle was as effective as 5,000 IU and 10,000 IU of urinary hCG in inducing final follicular maturation and early luteinisation in assisted reproductive technologies, and as effective as 5,000 IU of urinary hCG in ovulation induction.

So far, there are no signs of antibody development in humans to Ovitrelle. Repeated exposure to Ovitrelle was investigated in male patients only. Clinical investigation in women for the indication of ART and anovulation was limited to one treatment cycle.

5.2 Pharmacokinetic properties

Following intravenous administration, choriogonadotropin alfa is distributed to the extracellular fluid space with a distribution half-life of around 4.5 hours. The steady-state volume of distribution and the total clearance are 6 L and 0.2 L/h, respectively. There are no indications that choriogonadotropin alfa is metabolised and excreted differently than endogenous hCG.

Following subcutaneous administration, choriogonadotropin alfa is eliminated from the body with a terminal half-life of about 30 hours, and the absolute bioavailability is about 40%.

A comparative study between the freeze-dried and the liquid formulation showed bioequivalence between the two formulations.

5.3 Preclinical safety data

Nonclinical data reveal no special hazard for humans based on conventional studies of safety pharmacology, repeated dose toxicity and genotoxicity. Studies on carcinogenic potential were not performed. This is justified, given the proteinous nature of the active substance and the negative outcome of the genotoxicity testing.

Studies on reproduction were not performed in animals.

6. PHARMACEUTICAL PARTICULARS

6.1 List of excipients

Mannitol
Methionine
Poloxamer 188
Phosphoric acid (for pH adjustment)
Sodium hydroxide (for pH adjustment)
Water for injections

6.2 Incompatibilities

In the absence of compatibility studies, this medicinal product must not be mixed with other medicinal products.

6.3 Shelf life

2 years.

After opening, the medicinal product should be used immediately. However, the in-use stability has been demonstrated for 24 hours at + 2°C to 8°C.

6.4 Special precautions for storage

Store in a refrigerator (2°C - 8°C). Store in the original package. Within its shelf-life, the solution may be stored at or below 25°C for up to 30 days without being refrigerated again during this period. It must be discarded if not used after these 30 days.

6.5 Nature and contents of container

0.5 mL of solution in a pre-filled syringe (type I glass) with a plunger stopper (halobutyl rubber) and plunger (plastic), and with a needle for injection (stainless) – pack of 1.

6.6 Special precautions for disposal and other handling

Only clear solution without particles should be used.
For single use only.

Self-administration of Ovitrelle should only be performed by patients who are adequately trained and have access to expert advice.

Any unused medicinal product or waste material should be disposed of in accordance with local requirements.

7. MARKETING AUTHORISATION HOLDER

Merck Europe B.V.
Gustav Mahlerplein 102
1082 MA Amsterdam
The Netherlands

8. MARKETING AUTHORISATION NUMBER(S)

EU/1/00/165/007

9. DATE OF FIRST AUTHORISATION/RENEWAL OF THE AUTHORISATION

Date of first authorisation: 02 February 2001
Date of latest renewal: 02 February 2006

10. DATE OF REVISION OF THE TEXT

Detailed information on this medicinal product is available on the website of the European Medicines Agency <http://www.ema.europa.eu>.

1. NAME OF THE MEDICINAL PRODUCT

Ovitrelle 250 micrograms solution for injection in pre-filled pen

2. QUALITATIVE AND QUANTITATIVE COMPOSITION

Each pre-filled pen contains 250 micrograms choriogonadotropin alfa* (equivalent to approximately 6,500 IU).

* recombinant human chorionic gonadotropin, r-hCG produced in Chinese hamster ovary (CHO) cells by recombinant DNA technology.

For the full list of excipients, see section 6.1.

3. PHARMACEUTICAL FORM

Solution for injection in pre-filled pen.

Clear, colourless to slightly yellow solution.

The pH of the solution is 7.0 ± 0.3 , its osmolality 250-400 mOsm/kg.

4. CLINICAL PARTICULARS

4.1 Therapeutic indications

Ovitrelle is indicated in the treatment of:

- Adult women undergoing superovulation prior to assisted reproductive technologies (ART) such as *in vitro* fertilisation (IVF): Ovitrelle is administered to trigger final follicular maturation and luteinisation after stimulation of follicular growth,
- Anovulatory or oligo-ovulatory adult women: Ovitrelle is administered to trigger ovulation and luteinisation in anovulatory or oligo-ovulatory women after stimulation of follicular growth.

4.2 Posology and method of administration

Treatment with Ovitrelle should be performed under the supervision of a physician experienced in the treatment of fertility problems.

Posology

The maximum dose is 250 micrograms. The following dose regimen should be used:

- Women undergoing superovulation prior to assisted reproductive technologies (ART) such as *in vitro* fertilisation (IVF):

One pre-filled pen of Ovitrelle (250 micrograms) is administered 24 to 48 hours after the last administration of a follicle stimulating hormone (FSH) or human menopausal gonadotropin (hMG) preparation, i.e. when optimal stimulation of follicular growth is achieved.

- Anovulatory or oligo-ovulatory women:

One pre-filled pen of Ovitrelle (250 micrograms) is administered 24 to 48 hours after optimal stimulation of follicular growth is achieved. The patient is recommended to have coitus on the day of, and the day after, Ovitrelle injection.

Special populations

Renal or hepatic impairment

Safety, efficacy and pharmacokinetics of Ovitrelle in patients with renal or hepatic impairment have not been established.

Paediatric population

There is no relevant use of Ovitrelle in the paediatric population.

Method of administration

For subcutaneous use. Self-administration of Ovitrelle should only be performed by patients who are adequately trained and have access to expert advice. Ovitrelle is for single use only.

For instructions on the administration with the pre-filled pen, see section 6.6 and the “Instructions for use” provided in the carton.

4.3 Contraindications

- Hypersensitivity to the active substance or to any of the excipients listed in section 6.1
- Tumours of the hypothalamus or pituitary gland
- Ovarian enlargement or cyst unrelated to polycystic ovarian syndrome
- Gynaecological haemorrhages of unknown aetiology
- Ovarian, uterine or mammary carcinoma
- Active thromboembolic disorders

Ovitrelle must not be used in conditions when an effective response cannot be obtained, such as

- primary ovarian failure
- malformations of sexual organs incompatible with pregnancy
- fibroid tumours of the uterus incompatible with pregnancy
- postmenopausal women

4.4 Special warnings and precautions for use

Traceability

In order to improve the traceability of biological medicinal products, the name and the batch number of the administered product should be clearly recorded.

General precautions

Before starting treatment, the couple's infertility should be assessed as appropriate and putative contraindications for pregnancy evaluated. In particular, patients should be evaluated for hypothyroidism, adrenocortical deficiency, hyperprolactinemia and pituitary or hypothalamic tumours, and appropriate specific treatment given.

There is no clinical experience with Ovitrelle in the treatment of other conditions (such as corpus luteum insufficiency or male conditions); therefore, Ovitrelle is not indicated in these conditions.

Ovarian hyperstimulation syndrome (OHSS)

A certain degree of ovarian enlargement is an expected effect of controlled ovarian stimulation. It is more commonly seen in women with polycystic ovarian syndrome and usually regresses without treatment.

In distinction to uncomplicated ovarian enlargement, OHSS is a condition that can manifest itself with increasing degrees of severity. It comprises marked ovarian enlargement, high serum sex steroids, and an increase in vascular permeability which can result in an accumulation of fluid in the peritoneal, pleural and, rarely, in the pericardial cavities.

Mild manifestations of OHSS may include abdominal pain, abdominal discomfort and distension, and enlarged ovaries. Moderate OHSS may additionally present with nausea, vomiting, ultrasound evidence of ascites and marked ovarian enlargement.

Severe OHSS further includes symptoms such as severe ovarian enlargement, weight gain, dyspnoea or oliguria. Clinical evaluation may reveal signs such as hypovolaemia, haemoconcentration, electrolyte imbalances, ascites, pleural effusions, or acute pulmonary distress. Very rarely, severe OHSS may be complicated by ovarian torsion or thromboembolic events, such as pulmonary embolism, ischaemic stroke or myocardial infarction.

Independent risk factors for developing OHSS include young age, lean body mass, polycystic ovarian syndrome, higher doses of exogenous gonadotropins, high absolute or rapidly rising serum estradiol levels and previous episodes of OHSS, large number of developing ovarian follicles and large number of oocytes retrieved in ART cycles.

Adherence to recommended Ovitrelle dosage and regimen of administration can minimise the risk of ovarian hyperstimulation. Monitoring of stimulation cycles by ultrasound scans as well as estradiol measurements are recommended to early identify risk factors.

There is evidence to suggest that hCG plays a key role in triggering OHSS and that the syndrome may be more severe and more protracted if pregnancy occurs. Therefore, if signs of ovarian hyperstimulation occur, it is recommended that hCG be withheld and the patient be advised to refrain from coitus or use barrier contraceptive methods for at least 4 days.

As OHSS may progress rapidly (within 24 hours) or over several days to become a serious medical event, patients should be followed for at least two weeks after hCG administration.

Mild or moderate OHSS usually resolves spontaneously. If severe OHSS occurs, it is recommended that gonadotropin treatment be stopped and that the patient be hospitalised and appropriate therapy be started.

Multiple pregnancy

In patients undergoing induction of ovulation, the incidence of multiple pregnancy and births is increased compared with natural conception. The majority of multiple conceptions are twins. Multiple pregnancies, especially high order, carry an increased risk of adverse maternal and perinatal outcomes.

To minimise the risk of higher order multiple pregnancy, careful monitoring of ovarian response is recommended. In patients undergoing ART procedures the risk of multiple pregnancy is related mainly to the number of embryos replaced, their quality and the patient age.

Pregnancy loss

The incidence of pregnancy loss by miscarriage or abortion is higher in patients undergoing stimulation of follicular growth for ovulation induction or ART than following natural conception.

Ectopic pregnancy

Women with a history of tubal disease are at increased risk for ectopic pregnancy, whether the pregnancy is obtained by spontaneous conception or with fertility treatments. The prevalence of ectopic pregnancy after ART in this population was reported to be higher than in the general population.

Congenital malformations

The prevalence of congenital malformations after ART may be slightly higher than after spontaneous conceptions. This is thought to be due to differences in parental characteristics (e.g. maternal age, sperm characteristics) and the higher incidence of multiple pregnancies.

Thromboembolic events

In women with recent thromboembolic disease or women with generally recognised risk factors for thromboembolic events, such as personal or family history, treatment with gonadotropins may further increase the risk for aggravation or occurrence of such events. In these women, the benefits of gonadotropin administration need to be weighed against the risks. It should be noted, however, that pregnancy itself as well as OHSS also carry an increased risk of thromboembolic events.

Reproductive system neoplasms

There have been reports of ovarian and other reproductive system neoplasms, both benign and malignant, in women who have undergone multiple treatment regimens for infertility. It is not yet established whether or not treatment with gonadotropins increases the risk of these tumours in infertile women.

Interference with serum or urinary testing

Following administration, Ovitrelle may interfere for up to ten days with the immunological determination of serum or urinary hCG, potentially leading to a false positive pregnancy test. Patients should be made aware of this.

Sodium content

This medicinal product contains less than 1 mmol sodium (23 mg) per dose, i.e. it is essentially “sodium-free”.

4.5 Interaction with other medicinal products and other forms of interaction

No specific interaction studies with Ovitrelle and other medicinal products have been performed; however, no clinically significant medicinal product interactions have been reported during hCG therapy.

4.6 Fertility, pregnancy and lactation

Pregnancy

There is no indication for the use of Ovitrelle during pregnancy. Data on a limited number of exposed pregnancies indicate no increased risks of malformation or foeto/neonatal toxicity. No reproduction studies with choriogonadotropin alfa in animals were performed (see section 5.3). The potential risk for humans is unknown.

Breast-feeding

Ovitrelle is not indicated during breastfeeding. There are no data on the excretion of choriogonadotropin alfa in milk.

Fertility

Ovitrelle is indicated for use in infertility (see section 4.1).

4.7 Effects on ability to drive and use machines

Ovitrelle has no or negligible influence on the ability to drive and use machines.

4.8 Undesirable effects

Summary of the safety profile

In comparative trials with different doses of Ovitrelle, OHSS was found to be associated with Ovitrelle in a dose-related fashion. OHSS was observed in approximately 4% of patients treated with Ovitrelle. Severe OHSS was reported in less than 0.5% of patients (see section 4.4).

List of adverse reactions

The following definitions apply to the frequency terminology used hereafter: very common ($\geq 1/10$), common ($\geq 1/100$ to $< 1/10$), uncommon ($\geq 1/1,000$ to $< 1/100$), rare ($\geq 1/10,000$ to $< 1/1,000$), very rare ($< 1/10,000$), not known (cannot be estimated from the available data).

Immune system disorders

Very rare: Mild to severe hypersensitivity reactions including rash, anaphylactic reactions and shock

Nervous system disorders

Common: Headache

Vascular disorders

Very rare: Thromboembolism (both in association with and separate from OHSS)

Gastrointestinal disorders

Common: Abdominal pain, abdominal distension, nausea, vomiting

Uncommon: Abdominal discomfort, diarrhoea

Reproductive system and breast disorders

Common: Mild or moderate OHSS

Uncommon: Severe OHSS

General disorders and administration site conditions

Common: Injection site reactions.

Reporting of suspected adverse reactions

Reporting suspected adverse reactions after authorisation of the medicinal product is important. It allows continued monitoring of the benefit/risk balance of the medicinal product. Healthcare professionals are asked to report any suspected adverse reactions via the national reporting system listed in [Appendix V](#).

4.9 Overdose

The effects of an overdose of Ovitrelle are unknown. Nevertheless, there is a possibility that OHSS may result from an overdose of Ovitrelle (see section 4.4).

5. PHARMACOLOGICAL PROPERTIES

5.1 Pharmacodynamic properties

Pharmacotherapeutic group: Sex hormones and modulators of the genital system, gonadotropins, ATC code: G03GA08

Mechanism of action

Ovitrelle is a medicinal product of choriogonadotropin alfa produced by recombinant DNA techniques. It shares the amino acid sequence with urinary hCG. Chorionic gonadotropin binds on the ovarian theca (and granulosa) cells to a transmembrane receptor shared with the luteinising hormone, the LH/CG receptor.

Pharmacodynamic effects

The principal pharmacodynamic activity in women is oocyte meiosis resumption, follicular rupture (ovulation), corpus luteum formation and production of progesterone and estradiol by the corpus luteum.

In women, chorionic gonadotropin acts as a surrogate luteinising hormone surge that triggers ovulation.

Ovitrelle is used to trigger final follicular maturation and early luteinisation after use of medicinal products for stimulation of follicular growth.

Clinical efficacy and safety

In comparative clinical trials, administration of a dose of 250 micrograms of Ovitrelle was as effective as 5,000 IU and 10,000 IU of urinary hCG in inducing final follicular maturation and early luteinisation in assisted reproductive technologies, and as effective as 5,000 IU of urinary hCG in ovulation induction.

So far, there are no signs of antibody development in humans to Ovitrelle. Repeated exposure to Ovitrelle was investigated in male patients only. Clinical investigation in women for the indication of ART and anovulation was limited to one treatment cycle.

5.2 Pharmacokinetic properties

Following intravenous administration, choriogonadotropin alfa is distributed to the extracellular fluid space with a distribution half-life of around 4.5 hours. The steady-state volume of distribution and the total clearance are 6 L and 0.2 L/h, respectively. There are no indications that choriogonadotropin alfa is metabolised and excreted differently than endogenous hCG.

Following subcutaneous administration, choriogonadotropin alfa is eliminated from the body with a terminal half-life of about 30 hours, and the absolute bioavailability is about 40%.

A comparative study between the freeze-dried and the liquid formulation showed bioequivalence between the two formulations.

5.3 Preclinical safety data

Nonclinical data reveal no special hazard for humans based on conventional studies of safety pharmacology, repeated dose toxicity and genotoxicity. Studies on carcinogenic potential were not performed. This is justified, given the proteinous nature of the active substance and the negative outcome of the genotoxicity testing.

Studies on reproduction were not performed in animals.

6. PHARMACEUTICAL PARTICULARS

6.1 List of excipients

Mannitol
Methionine
Disodium phosphate dihydrate
Sodium dihydrogen phosphate monohydrate
Poloxamer 188
Phosphoric acid (for pH adjustment)
Sodium hydroxide (for pH adjustment)
Water for injections

6.2 Incompatibilities

In the absence of compatibility studies, this medicinal product must not be mixed with other medicinal products.

6.3 Shelf life

2 years.

After opening, the medicinal product should be used immediately.

6.4 Special precautions for storage

Store in a refrigerator (2°C - 8°C). Do not freeze.

6.5 Nature and contents of container

3 mL cartridge (type I glass, with a bromobutyl rubber plunger stopper and an aluminium crimp cap with bromobutyl rubber) preassembled in a pre-filled pen. Each pre-filled pen contains 0.5 mL of solution for injection.

Pack of 1 pre-filled pen and 1 injection needle.

6.6 Special precautions for disposal and other handling

See the "Instructions for use" provided in the carton.

Only clear solution without particles should be used. Use each needle and pen only once.

Self-administration of Ovitrelle should only be performed by patients who are adequately trained and have access to expert advice.

Any unused medicinal product or waste material should be disposed of in accordance with local requirements.

7. MARKETING AUTHORISATION HOLDER

Merck Europe B.V.
Gustav Mahlerplein 102
1082 MA Amsterdam
The Netherlands

8. MARKETING AUTHORISATION NUMBER(S)

EU/1/00/165/008

9. DATE OF FIRST AUTHORISATION/RENEWAL OF THE AUTHORISATION

Date of first authorisation: 02 February 2001
Date of latest renewal: 02 February 2006

10. DATE OF REVISION OF THE TEXT

Detailed information on this medicinal product is available on the website of the European Medicines Agency <http://www.ema.europa.eu>.

ANNEX II

- A. MANUFACTURER OF THE BIOLOGICAL ACTIVE SUBSTANCE AND MANUFACTURER RESPONSIBLE FOR BATCH RELEASE**
- B. CONDITIONS OR RESTRICTIONS REGARDING SUPPLY AND USE**
- C. OTHER CONDITIONS AND REQUIREMENTS OF THE MARKETING AUTHORISATION**
- D. CONDITIONS OR RESTRICTIONS WITH REGARD TO THE SAFE AND EFFECTIVE USE OF THE MEDICINAL PRODUCT**

A. MANUFACTURER OF THE BIOLOGICAL ACTIVE SUBSTANCE AND MANUFACTURER RESPONSIBLE FOR BATCH RELEASE

Name and address of the manufacturer of the biological active substance

Merck Serono S.A.
Zone Industrielle de l'Ourietta
1170 Aubonne
Switzerland

Name and address of the manufacturer responsible for batch release

Merck Serono S.p.A.
Via delle Magnolie 15
70026 Modugno (Bari)
Italy

B. CONDITIONS OR RESTRICTIONS REGARDING SUPPLY AND USE

Medicinal product subject to restricted medical prescription (see Annex I: Summary of Product Characteristics, section 4.2).

C. OTHER CONDITIONS AND REQUIREMENTS OF THE MARKETING AUTHORISATION

• **Periodic safety update reports (PSURs)**

The requirements for submission of PSURs for this medicinal product are set out in the list of Union reference dates (EURD list) provided for under Article 107c(7) of Directive 2001/83/EC and any subsequent updates published on the European medicines web-portal.

D. CONDITIONS OR RESTRICTIONS WITH REGARD TO THE SAFE AND EFFECTIVE USE OF THE MEDICINAL PRODUCT

• **Risk management plan (RMP)**

The marketing authorisation holder (MAH) shall perform the required pharmacovigilance activities and interventions detailed in the agreed RMP presented in Module 1.8.2 of the marketing authorisation and any agreed subsequent updates of the RMP.

An updated RMP should be submitted:

- At the request of the European Medicines Agency;
- Whenever the risk management system is modified, especially as the result of new information being received that may lead to a significant change to the benefit/risk profile or as the result of an important (pharmacovigilance or risk minimisation) milestone being reached.

ANNEX III
LABELLING AND PACKAGE LEAFLET

A. LABELLING

PARTICULARS TO APPEAR ON THE OUTER PACKAGING

BOX OF 1 PRE-FILLED SYRINGE

1. NAME OF THE MEDICINAL PRODUCT

Ovitrelle 250 micrograms/0.5 mL solution for injection in pre-filled syringe
choriogonadotropin alfa

2. STATEMENT OF ACTIVE SUBSTANCE(S)

Each pre-filled syringe contains 250 micrograms (6,500 IU) choriogonadotropin alfa.

3. LIST OF EXCIPIENTS

Mannitol, methionine, poloxamer 188, phosphoric acid (for pH adjustment), sodium hydroxide (for pH adjustment), water for injections.

4. PHARMACEUTICAL FORM AND CONTENTS

1 pre-filled syringe with 0.5 mL solution for injection

5. METHOD AND ROUTE(S) OF ADMINISTRATION

For single use only.
Read the package leaflet before use.
Subcutaneous use.

6. SPECIAL WARNING THAT THE MEDICINAL PRODUCT MUST BE STORED OUT OF THE SIGHT AND REACH OF CHILDREN

Keep out of the sight and reach of children.

7. OTHER SPECIAL WARNING(S), IF NECESSARY

8. EXPIRY DATE

EXP

9. SPECIAL STORAGE CONDITIONS

Store in a refrigerator. Store in the original package. May be stored at or below +25°C for up to 30 days without being refrigerated again during this period and must be discarded if not used during these 30 days.

10. SPECIAL PRECAUTIONS FOR DISPOSAL OF UNUSED MEDICINAL PRODUCTS OR WASTE MATERIALS DERIVED FROM SUCH MEDICINAL PRODUCTS, IF APPROPRIATE

11. NAME AND ADDRESS OF THE MARKETING AUTHORISATION HOLDER

Merck Europe B.V.
Gustav Mahlerplein 102
1082 MA Amsterdam
The Netherlands

12. MARKETING AUTHORISATION NUMBER(S)

EU/1/00/165/007

13. BATCH NUMBER

Batch

14. GENERAL CLASSIFICATION FOR SUPPLY

15. INSTRUCTIONS ON USE

16. INFORMATION IN BRAILLE

ovitrelle 250/0.5 ml

17. UNIQUE IDENTIFIER – 2D BARCODE

2D barcode carrying the unique identifier included.

18. UNIQUE IDENTIFIER - HUMAN READABLE DATA

PC
SN
NN

**MINIMUM PARTICULARS TO APPEAR ON SMALL IMMEDIATE PACKAGING UNITS
PRE-FILLED SYRINGE LABEL**

1. NAME OF THE MEDICINAL PRODUCT AND ROUTE(S) OF ADMINISTRATION

Ovitrelle 250 micrograms/0.5 mL solution for injection
choriogonadotropin alfa
Subcutaneous use.

2. METHOD OF ADMINISTRATION

3. EXPIRY DATE

EXP

4. BATCH NUMBER

Batch

5. CONTENTS BY WEIGHT, BY VOLUME OR BY UNIT

250 micrograms/0.5 mL

6. OTHER

PARTICULARS TO APPEAR ON THE OUTER PACKAGING

BOX OF 1 PRE-FILLED PEN

1. NAME OF THE MEDICINAL PRODUCT

Ovitrelle 250 micrograms solution for injection in pre-filled pen
choriogonadotropin alfa

2. STATEMENT OF ACTIVE SUBSTANCE(S)

Each pre-filled pen contains 250 micrograms (approximately 6,500 IU) choriogonadotropin alfa.

3. LIST OF EXCIPIENTS

Mannitol, methionine, disodium phosphate dihydrate, sodium dihydrogen phosphate monohydrate, poloxamer 188, phosphoric acid (for pH adjustment), sodium hydroxide (for pH adjustment), water for injections.

4. PHARMACEUTICAL FORM AND CONTENTS

Solution for injection
1 pre-filled pen of 0.5 mL solution
1 injection needle

5. METHOD AND ROUTE(S) OF ADMINISTRATION

For single use only.
Read the package leaflet before use.
Subcutaneous use

6. SPECIAL WARNING THAT THE MEDICINAL PRODUCT MUST BE STORED OUT OF THE SIGHT AND REACH OF CHILDREN

Keep out of the sight and reach of children

7. OTHER SPECIAL WARNING(S), IF NECESSARY

8. EXPIRY DATE

EXP

9. SPECIAL STORAGE CONDITIONS

Store in a refrigerator. Do not freeze.

10. SPECIAL PRECAUTIONS FOR DISPOSAL OF UNUSED MEDICINAL PRODUCTS OR WASTE MATERIALS DERIVED FROM SUCH MEDICINAL PRODUCTS, IF APPROPRIATE

11. NAME AND ADDRESS OF THE MARKETING AUTHORISATION HOLDER

Merck Europe B.V.
Gustav Mahlerplein 102
1082 MA Amsterdam
The Netherlands

12. MARKETING AUTHORISATION NUMBER(S)

EU/1/00/165/008

13. BATCH NUMBER

Batch

14. GENERAL CLASSIFICATION FOR SUPPLY

15. INSTRUCTIONS ON USE

16. INFORMATION IN BRAILLE

ovitrelle 250 pen

17. UNIQUE IDENTIFIER – 2D BARCODE

2D barcode carrying the unique identifier included.

18. UNIQUE IDENTIFIER - HUMAN READABLE DATA

PC
SN
NN

**MINIMUM PARTICULARS TO APPEAR ON SMALL IMMEDIATE PACKAGING UNITS
PRE-FILLED PEN LABEL**

1. NAME OF THE MEDICINAL PRODUCT AND ROUTE(S) OF ADMINISTRATION

Ovitrelle 250 micrograms solution for injection
choriogonadotropin alfa
Subcutaneous use.

2. METHOD OF ADMINISTRATION

3. EXPIRY DATE

EXP

4. BATCH NUMBER

Batch

5. CONTENTS BY WEIGHT, BY VOLUME OR BY UNIT

250 micrograms/0.5 mL

6. OTHER

B. PACKAGE LEAFLET

Package leaflet: Information for the user

Ovitrelle 250 micrograms/0.5 mL solution for injection in pre-filled syringe choriogonadotropin alfa

Read all of this leaflet carefully before you start using this medicine because it contains important information for you.

- Keep this leaflet. You may need to read it again.
- If you have any further questions, ask your doctor or pharmacist.
- This medicine has been prescribed for you only. Do not pass it on to others. It may harm them, even if their signs of illness are the same as yours.
- If you get any side effects, talk to your doctor or pharmacist. This includes any possible side effects not listed in this leaflet. See section 4.

What is in this leaflet

1. What Ovitrelle is and what it is used for
2. What do you need to know before you use Ovitrelle
3. How to use Ovitrelle
4. Possible side effects
5. How to store Ovitrelle
6. Contents of the pack and other information

1. What Ovitrelle is and what it is used for

What Ovitrelle is

Ovitrelle contains a medicine called ‘choriogonadotropin alfa’, made in a laboratory by a special recombinant DNA technique. Choriogonadotropin alfa is similar to a hormone found naturally in your body called ‘chorionic gonadotropin’, which is involved in reproduction and fertility.

What Ovitrelle is used for

Ovitrelle is used together with other medicines:

- To help develop and ripen several follicles (each containing an egg) in women undergoing assisted reproductive technologies (procedure that may help you to become pregnant) such as ‘*in vitro* fertilisation’. Other medicines will be given first to bring about the growth of several follicles.
- To help release an egg from the ovary (ovulation induction) in women who cannot produce eggs (‘anovulation’), or women who produce too few eggs (‘oligo-ovulation’). Other medicines will be given first to develop and ripen the follicles.

2. What do you need to know before you use Ovitrelle

Do not use Ovitrelle

- if you are allergic to choriogonadotropin alfa or any of the other ingredients of this medicine (listed in section 6).
- if you have a tumour in your hypothalamus or pituitary gland (both are parts of the brain).
- if you have large ovaries or sacs of fluid within the ovaries (ovarian cysts) of unknown origin.
- if you have unexplained vaginal bleeding.
- if you have cancer of your ovaries, womb or breast.
- if you have severe inflammation of your veins or blood clotting in your veins (active thromboembolic disorders).

- if you have any condition that usually makes a normal pregnancy impossible, such as menopause or early menopause (ovarian failure), or malformations of sexual organs.

Do not use Ovitrelle if any of the above applies to you. If you are not sure, talk to your doctor before using this medicine.

Warnings and precautions

Before the treatment is started, your and your partner's fertility should be evaluated by a doctor experienced in the treatment of fertility problems.

Ovarian hyperstimulation syndrome (OHSS)

This medicine may increase your risk of developing OHSS. This is when your follicles develop too much and become large cysts.

If you get lower abdominal pain, gain any weight rapidly, feel sick or are vomiting, or have difficulty in breathing, do not give yourself the Ovitrelle injection and talk to your doctor straight away (see section 4). If you are developing OHSS, you may be told not to have sex or to use a barrier contraceptive method for at least four days.

The risk of OHSS is reduced if the usual dose of Ovitrelle is used, and if you are monitored closely throughout your treatment cycle (e.g. blood tests for estradiol levels and ultrasound).

Multiple pregnancy and/or birth defects

When using Ovitrelle, you have a higher risk of being pregnant with more than one child at the same time ('multiple pregnancy', usually twins) than if you conceived naturally. Multiple pregnancy may lead to medical complications for you and your babies. When undergoing assisted reproductive technologies, the risk of having a multiple pregnancy is related to your age, the quality and the number of fertilised eggs or embryos placed inside you. Multiple pregnancies and specific characteristics of couples with fertility problems (e.g. age) may also be associated with an increased chance of birth defects.

The risk of multiple pregnancy is reduced if you are monitored closely throughout your treatment cycle (e.g. blood tests for estradiol levels and ultrasound).

Ectopic pregnancy

Pregnancy outside of the womb (an ectopic pregnancy) may occur in women with damaged fallopian tubes (the tubes which carry the egg from the ovary to the womb). Therefore, your doctor should perform an early ultrasound examination to rule out the possibility of pregnancy outside the womb.

Miscarriage

When undergoing assisted reproductive technologies or stimulation of your ovaries to produce eggs, you are more likely to have a miscarriage than the average woman.

Blood clotting problems (thromboembolic events)

Talk to your doctor before using Ovitrelle if you or a member of your family have ever had blood clots in the leg or in the lung, or a heart attack or stroke. You may be at a higher risk of serious blood clots or existing clots might become worse with Ovitrelle treatment.

Tumours of sexual organs

There have been reports of tumours in the ovaries and other sex organs, both benign and malignant, in women who have undergone multiple regimens for infertility treatment.

Pregnancy tests

If you do a pregnancy test with serum or urine after use of Ovitrelle, and up to ten days later, it may happen that you get a false positive test result. If you are not sure, talk to your doctor.

Children and adolescents

Ovitrelle is not for use in children and adolescents.

Other medicines and Ovitrelle

Tell your doctor if you are taking, have recently taken or might take any other medicines.

Pregnancy and breast-feeding

Do not use Ovitrelle if you are pregnant or breast-feeding.

If you are pregnant or breast-feeding, ask your doctor for advice before taking this medicine.

Driving and using machines

It is not expected that Ovitrelle will affect your ability to drive and use machines.

Ovitrelle contains sodium

This medicine contains less than 1 mmol sodium (23 mg) per dose, that is to say essentially “sodium-free”.

3. How to use Ovitrelle

Always use this medicine exactly as your doctor has told you. Check with your doctor or pharmacist if you are not sure.

How much to use

- The recommended dose is 1 pre-filled syringe (250 micrograms/0.5 mL) given as a single injection.
- Your doctor will have explained exactly when to give the injection.

Using this medicine

- Ovitrelle is intended for subcutaneous use that means given by injection under the skin.
- Each pre-filled syringe is for single use only. Only clear solution without particles should be used.
- Your doctor or nurse will show you how to use the Ovitrelle pre-filled syringe to inject the medicine.
- Inject Ovitrelle as your doctor or nurse taught you.
- After the injection, dispose of the used syringe safely.

If you administer Ovitrelle to yourself, please carefully read the following instructions:

1. Wash your hands. It is important that your hands and the items you use are as clean as possible.

2. Assemble everything you need. Please note that alcohol swabs are not contained in the package. Find a clean area and lay out everything:
- two alcohol swabs,
 - one pre-filled syringe containing the medicinal product.

3. Injection:

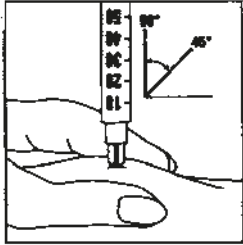

Immediately inject the solution: Your doctor or nurse will have already advised you where to inject (e.g. tummy, front of thigh). Wipe the chosen area with an alcohol swab. Firmly pinch the skin together and insert the needle for injection at a 45° to 90° angle using a dart-like motion. Inject under the skin, as you were taught. Do not inject directly into a vein. Inject the solution by pushing gently on the plunger. Take as much time as you need to inject all the solution. Immediately withdraw the needle and clean the skin with an alcohol swab using a circular motion.

4. Dispose of all used items:
Once you have finished your injection, immediately discard the empty syringe in a sharps container. Any unused solution must be discarded.

If you use more Ovitrelle than you should

The effects of an overdose of Ovitrelle are unknown, nevertheless there is a possibility that ovarian hyperstimulation syndrome (OHSS) may occur, which is further described in section 4.

If you forget to use Ovitrelle

If you forget to use Ovitrelle, please talk to your doctor as soon as you notice.

If you have any further questions on the use of this medicine, ask your doctor or pharmacist.

4. Possible side effects

Like all medicines, this medicine can cause side effects, although not everybody gets them.

Stop using Ovitrelle and see a doctor straight away if you notice any of the following serious side effects – you may need urgent medical treatment:

- Allergic reactions such as rash, fast or uneven pulse, swelling of your tongue and throat, sneezing, wheezing, or serious breathing difficulty are very rare (may affect up to 1 in 10,000 people).
- Lower abdominal pain, abdominal distension or abdominal discomfort together with nausea (feeling sick) or vomiting may be the symptoms of ovarian hyperstimulation syndrome (OHSS). This may indicate that the ovaries over-reacted to the treatment and that large ovarian cysts developed (see also in section 2. under “Ovarian hyperstimulation syndrome”). This event is common (may affect up to 1 in 10 people).
- The OHSS may become severe with clearly enlarged ovaries, decreased urine production, weight gain, difficulty in breathing and possible fluid accumulation in your stomach or chest. This event is uncommon (may affect up to 1 in 100 people).
- Serious blood clotting complications (thromboembolic events) sometimes independent of OHSS may be found very rarely. This could cause chest pain, breathlessness, stroke or heart attack (see also in section 2. under “Blood clotting problems”).

Other side effects

Common (may affect up to 1 in 10 people)

- Headache.
- Local reactions at the injection site, such as pain, redness or swelling.

Uncommon (may affect up to 1 in 100 people)

- Diarrhoea.

Reporting of side effects

If you get any side effects, talk to your doctor or pharmacist. This includes any possible side effects not listed in this leaflet. You can also report side effects directly via the national reporting system listed in [Appendix V](#). By reporting side effects you can help provide more information on the safety of this medicine.

5. How to store Ovitrelle

Keep this medicine out of the sight and reach of children.

Do not use this medicine after the expiry date which is stated on the label and carton after EXP. The expiry date refers to the last day of that month.

Store in a refrigerator (2°C - 8°C). Store in the original package. Ovitrelle 250 micrograms solution for injection may be stored at room temperature (at or below +25°C) for up to 30 days without being refrigerated again during this period, and must be discarded if not used during these 30 days.

Do not throw away any medicine via wastewater or household waste. Ask your pharmacist how to throw away medicines no longer used. These measures will help protect the environment.

6. Contents of the pack and other information

What Ovitrelle contains

- The active substance is choriogonadotropin alfa, produced by recombinant DNA technology.
- Each pre-filled syringe contains 250 micrograms / 0.5 mL (equivalent to 6500 IU).
- The other ingredients are mannitol, methionine, poloxamer 188, phosphoric acid, sodium hydroxide, water for injections.

What Ovitrelle looks like and contents of the pack

Ovitrelle is provided as solution for injection. It is available as a single pre-filled syringe (pack of 1).

Marketing Authorisation Holder

Merck Europe B.V., Gustav Mahlerplein 102, 1082 MA Amsterdam, The Netherlands

Manufacturer

Merck Serono S.p.A., Via delle Magnolie 15, 70026 Modugno (Bari), Italy

This leaflet was last revised in

Detailed information on this medicine is available on the European Medicines Agency web site:
<http://www.ema.europa.eu>.

Package leaflet: Information for the user

Ovitrelle 250 micrograms solution for injection in pre-filled pen choriogonadotropin alfa

Read all of this leaflet carefully before you start using this medicine because it contains important information for you.

- Keep this leaflet. You may need to read it again.
- If you have any further questions, ask your doctor or pharmacist.
- This medicine has been prescribed for you only. Do not pass it on to others. It may harm them, even if their signs of illness are the same as yours.
- If you get any side effects, talk to your doctor or pharmacist. This includes any possible side effects not listed in this leaflet. See section 4.

What is in this leaflet

1. What Ovitrelle is and what it is used for
2. What do you need to know before you use Ovitrelle
3. How to use Ovitrelle
4. Possible side effects
5. How to store Ovitrelle
6. Contents of the pack and other information

1. What Ovitrelle is and what it is used for

What Ovitrelle is

Ovitrelle contains a medicine called ‘choriogonadotropin alfa’, made in a laboratory by a special recombinant DNA technique. Choriogonadotropin alfa is similar to a hormone found naturally in your body called ‘chorionic gonadotropin’, which is involved in reproduction and fertility.

What Ovitrelle is used for

Ovitrelle is used together with other medicines:

- To help develop and ripen several follicles (each containing an egg) in women undergoing assisted reproductive technologies (procedure that may help you to become pregnant) such as ‘*in vitro* fertilisation’. Other medicines will be given first to bring about the growth of several follicles.
- To help release an egg from the ovary (ovulation induction) in women who cannot produce eggs (‘anovulation’), or women who produce too few eggs (‘oligo-ovulation’). Other medicines will be given first to develop and ripen the follicles.

2. What do you need to know before you use Ovitrelle

Do not use Ovitrelle

- if you are allergic to choriogonadotropin alfa or any of the other ingredients of this medicine (listed in section 6).
- if you have a tumour in your hypothalamus or pituitary gland (both are parts of the brain).
- if you have large ovaries or sacs of fluid within the ovaries (ovarian cysts) of unknown origin.
- if you have unexplained vaginal bleeding.
- if you have cancer of your ovaries, womb or breast.
- if you have severe inflammation of your veins or blood clotting in your veins (active thromboembolic disorders).

- if you have any condition that usually makes a normal pregnancy impossible, such as menopause or early menopause (ovarian failure), or malformations of sexual organs.

Do not use Ovitrelle if any of the above applies to you. If you are not sure, talk to your doctor before using this medicine.

Warnings and precautions

Before the treatment is started, your and your partner's fertility should be evaluated by a doctor experienced in the treatment of fertility problems.

Ovarian hyperstimulation syndrome (OHSS)

This medicine may increase your risk of developing OHSS. This is when your follicles develop too much and become large cysts.

If you get lower abdominal pain, gain any weight rapidly, feel sick or are vomiting, or have difficulty in breathing, do not give yourself the Ovitrelle injection and talk to your doctor straight away (see section 4). If you are developing OHSS, you may be told not to have sex or to use a barrier contraceptive method for at least four days.

The risk of OHSS is reduced if the usual dose of Ovitrelle is used, and if you are monitored closely throughout your treatment cycle (e.g. blood tests for estradiol levels and ultrasound).

Multiple pregnancy and/or birth defects

When using Ovitrelle, you have a higher risk of being pregnant with more than one child at the same time ('multiple pregnancy', usually twins) than if you conceived naturally. Multiple pregnancy may lead to medical complications for you and your babies. When undergoing assisted reproductive technologies, the risk of having a multiple pregnancy is related to your age, the quality and the number of fertilised eggs or embryos placed inside you. Multiple pregnancies and specific characteristics of couples with fertility problems (e.g. age) may also be associated with an increased chance of birth defects.

The risk of multiple pregnancy is reduced if you are monitored closely throughout your treatment cycle (e.g. blood tests for estradiol levels and ultrasound).

Ectopic pregnancy

Pregnancy outside of the womb (an ectopic pregnancy) may occur in women with damaged fallopian tubes (the tubes which carry the egg from the ovary to the womb). Therefore, your doctor should perform an early ultrasound examination to rule out the possibility of pregnancy outside the womb.

Miscarriage

When undergoing assisted reproductive technologies or stimulation of your ovaries to produce eggs, you are more likely to have a miscarriage than the average woman.

Blood clotting problems (thromboembolic events)

Talk to your doctor before using Ovitrelle if you or a member of your family have ever had blood clots in the leg or in the lung, or a heart attack or stroke. You may be at a higher risk of serious blood clots or existing clots might become worse with Ovitrelle treatment.

Tumours of sexual organs

There have been reports of tumours in the ovaries and other sex organs, both benign and malignant, in women who have undergone multiple regimens for infertility treatment.

Pregnancy tests

If you do a pregnancy test with serum or urine after use of Ovitrelle, and up to ten days later, it may happen that you get a false positive test result. If you are not sure, talk to your doctor.

Children and adolescents

Ovitrelle is not for use in children and adolescents.

Other medicines and Ovitrelle

Tell your doctor if you are taking, have recently taken or might take any other medicines.

Pregnancy and breast-feeding

Do not use Ovitrelle if you are pregnant or breast-feeding.

If you are pregnant or breast-feeding, ask your doctor for advice before taking this medicine.

Driving and using machines

It is not expected that Ovitrelle will affect your ability to drive and use machines.

Ovitrelle contains sodium

This medicine contains less than 1 mmol sodium (23 mg) per dose, that is to say essentially “sodium-free”.

3. How to use Ovitrelle

Always use this medicine exactly as your doctor has told you. Check with your doctor or pharmacist if you are not sure.

How much to use

- The recommended dose is 1 pre-filled pen (250 micrograms/0.5 mL) given as a single injection.
- Your doctor will explain to you exactly when to give the injection.

Using this medicine

- If you administer Ovitrelle to yourself, please carefully read and follow the separate “Instructions for use” provided in the carton.
- Ovitrelle is intended to be given by injection under the skin (subcutaneously).
- Each pre-filled pen is for single use only.
- Your doctor or nurse will show you how to use the Ovitrelle pre-filled pen to inject the medicine.
- Inject Ovitrelle as your doctor or nurse taught you.
- After the injection, dispose of the used needle safely, and discard the pen.

If you use more Ovitrelle than you should

The effects of an overdose of Ovitrelle are unknown, nevertheless there is a possibility that ovarian hyperstimulation syndrome (OHSS) may occur, which is further described in section 4.

If you forget to use Ovitrelle

If you forget to use Ovitrelle, please talk to your doctor as soon as you notice.

If you have any further questions on the use of this medicine, ask your doctor or pharmacist.

4. Possible side effects

Like all medicines, this medicine can cause side effects, although not everybody gets them.

Stop using Ovitrelle and see a doctor straight away if you notice any of the following serious side effects – you may need urgent medical treatment:

- Allergic reactions such as rash, fast or uneven pulse, swelling of your tongue and throat, sneezing, wheezing, or serious breathing difficulty are very rare (may affect up to 1 in 10,000 people).
- Lower abdominal pain, abdominal distension or abdominal discomfort together with nausea (feeling sick) or vomiting may be the symptoms of ovarian hyperstimulation syndrome (OHSS). This may indicate that the ovaries over-reacted to the treatment and that large ovarian cysts developed (see also in section 2. under “Ovarian hyperstimulation syndrome”). This event is common (may affect up to 1 in 10 people).
- The OHSS may become severe with clearly enlarged ovaries, decreased urine production, weight gain, difficulty in breathing and possible fluid accumulation in your stomach or chest. This event is uncommon (may affect up to 1 in 100 people).
- Serious blood clotting complications (thromboembolic events) sometimes independent of OHSS may be found very rarely. This could cause chest pain, breathlessness, stroke or heart attack (see also in section 2. under “Blood clotting problems”).

Other side effects

Common (may affect up to 1 in 10 people)

- Headache.
- Local reactions at the injection site, such as pain, redness or swelling.

Uncommon (may affect up to 1 in 100 people)

- Diarrhoea.

Reporting of side effects

If you get any side effects, talk to your doctor or pharmacist. This includes any possible side effects not listed in this leaflet. You can also report side effects directly via the national reporting system listed in [Appendix V](#). By reporting side effects you can help provide more information on the safety of this medicine.

5. How to store Ovitrelle

Keep this medicine out of the sight and reach of children.

Do not use this medicine after the expiry date which is stated on the label and carton after EXP. The expiry date refers to the last day of that month.

Store in a refrigerator (2°C-8°C). Do not freeze.

Do not use Ovitrelle if you notice any signs of deterioration, if the liquid contains particles or is not clear.

Do not throw away any medicine via wastewater or household waste. Ask your pharmacist how to throw away medicines no longer used. These measures will help to protect the environment.

6. Contents of the pack and other information

What Ovitrelle contains

- The active substance is choriogonadotropin alfa, produced by recombinant DNA technology.
- Each pre-filled pen contains 250 micrograms choriogonadotropin alfa in 0.5 mL (equivalent to approximately 6,500 International Units, IU).
- The other ingredients are mannitol, methionine disodium phosphate dihydrate, sodium dihydrogen phosphate monohydrate, poloxamer 188, phosphoric acid (for pH adjustment), sodium hydroxide (for pH adjustment) and water for injections.

What Ovitrelle looks like and contents of the pack

- Ovitrelle comes as a clear, colourless to slightly yellow liquid for injection in a pre-filled pen.
- Each pen contains 0.5 mL of solution.
- It is supplied in packs of 1 pre-filled pen and 1 injection needle.

Marketing Authorisation Holder

Merck Europe B.V., Gustav Mahlerplein 102, 1082 MA Amsterdam, The Netherlands

Manufacturer

Merck Serono S.p.A., Via delle Magnolie 15, 70026 Modugno (Bari), Italy

This leaflet was last revised in

Detailed information on this medicine is available on the European Medicines Agency web site:
<http://www.ema.europa.eu>.

Instructions For Use
OVITRELLE 250 micrograms solution for injection in pre-filled pen
Choriogonadotropin alfa

CONTENTS

1. **How to use your Ovitrelle pre-filled pen**
 2. **Before you start using your Ovitrelle pre-filled pen**
 3. **Getting your Ovitrelle pre-filled pen ready for injection**
 4. **Setting the dose – “How to set the dose to 250”**
 5. **Injecting the dose**
 6. **After the injection**
-

Warning: Please read these instructions for use before using your Ovitrelle pre-filled pen. Follow the procedure exactly, as it may differ from your past experience.

1. How to use your Ovitrelle pre-filled pen

- The pen is for subcutaneous injection only.
- Inject Ovitrelle as your doctor or nurse taught you.
- **This pen is for single use only.** Do not share the pen.

2. Before you start using your Ovitrelle pre-filled pen

- Wash your hands with soap and water.
- Find a clean area and a **flat surface**.
- Verify the **expiration date** on the pen label.
- Gather everything you need and lay it out:

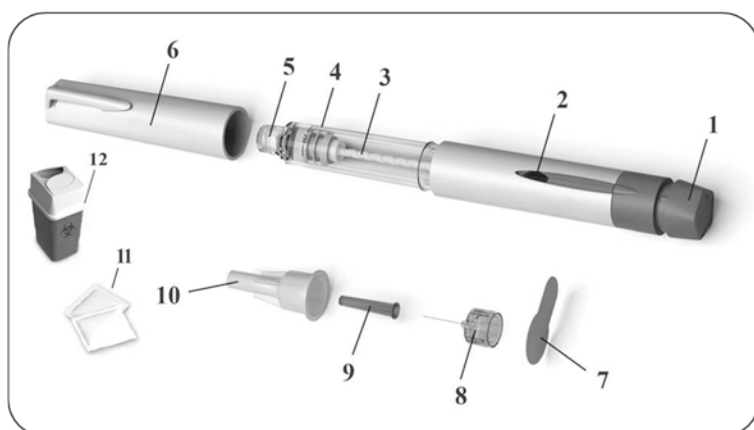

- | | |
|------------------------------|-------------------------------|
| 1. dose setting knob | 7. peel-off seal tab |
| 2. dose display | 8. removable needle |
| 3. plunger piston | 9. inner needle shield |
| 4. reservoir holder | 10. outer needle cap |
| 5. threaded needle connector | 11. alcohol swabs |
| 6. pen cap | 12. sharps disposal container |

Please note: alcohol swabs and sharps disposal container are not provided in the pack.

3. Getting your Ovitrelle pre-filled pen ready for injection

3.1 Take off the pen cap

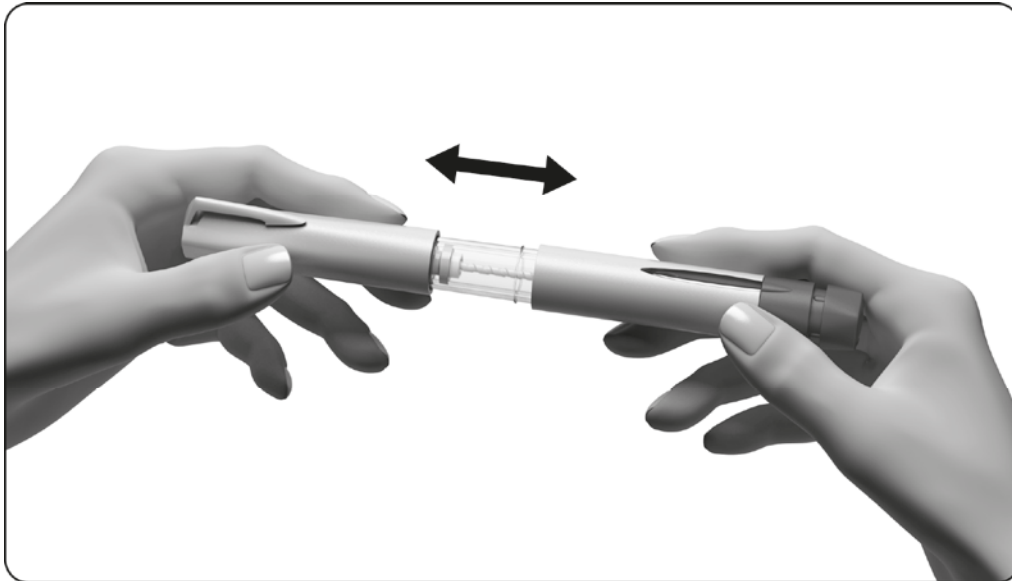

3.2 Prepare your needle for injection

- Get a new needle - only use the 'single use' needle supplied.
- Hold the outer needle cap firmly.
- Check that the peel-off seal on the outer needle cap is not damaged or loose.
- Remove the peel-off seal.



CAUTION:

If the peel-off seal is damaged or loose, do not use the needle. Throw it away in a sharps disposal container. Ask your doctor or pharmacist how to get a new needle.

3.3. Attach the needle

- Screw the threaded tip of the Ovitrelle pre-filled pen into the outer needle cap until you feel a light resistance.
Warning: Do not attach the needle too tightly; the needle could be difficult to remove after the injection.



- Remove the outer needle cap by pulling it gently.

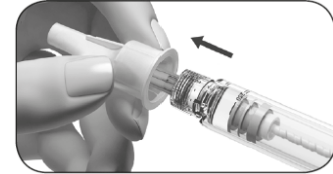

Put it aside for later use.

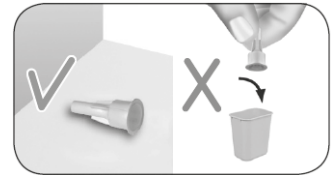

- Hold the Ovitrelle pre-filled pen with the needle pointing upward.
- Carefully remove and discard the green inner shield.

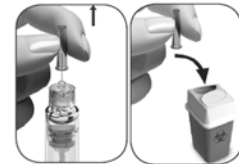

3.4. Look closely at the tip of the needle for tiny drop(s) of fluid

- If you see a tiny drop(s) of fluid proceed to **Section 4: Setting the dose to 250.**

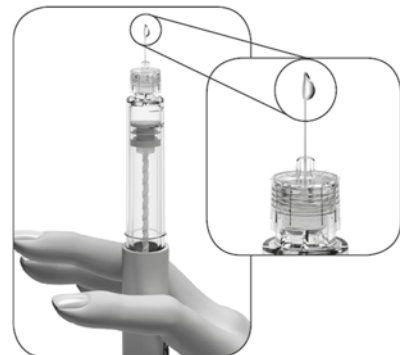

CAUTION:

If you do not see a tiny drop(s) at or near the needle tip, you must perform the steps on the next page.

If you do not see a tiny drop(s) of fluid at or near the tip:

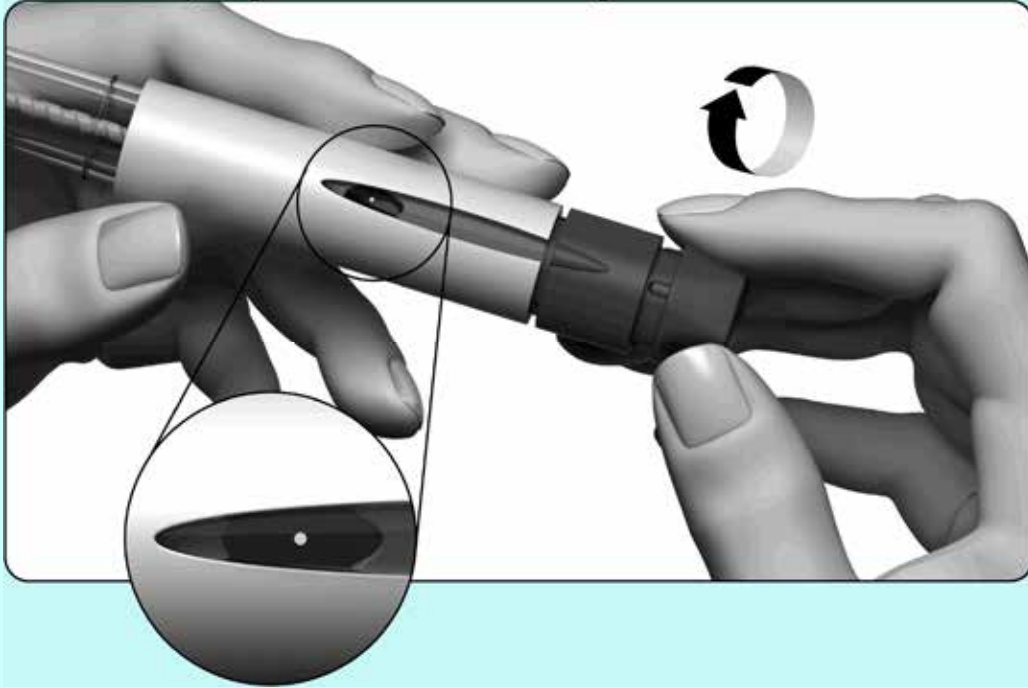

1. Gently turn the dose setting knob clockwise until you see a dot (●) in the dose display. If you pass this position, simply turn the dose setting knob back to the dot (●).
2. Hold the pen with the needle pointing upward.
3. Tap the reservoir holder gently.
4. Press the dose setting knob **as far as it will go**. A tiny drop of liquid will appear at the top of the needle; this shows that your pre-filled pen is ready for injection.

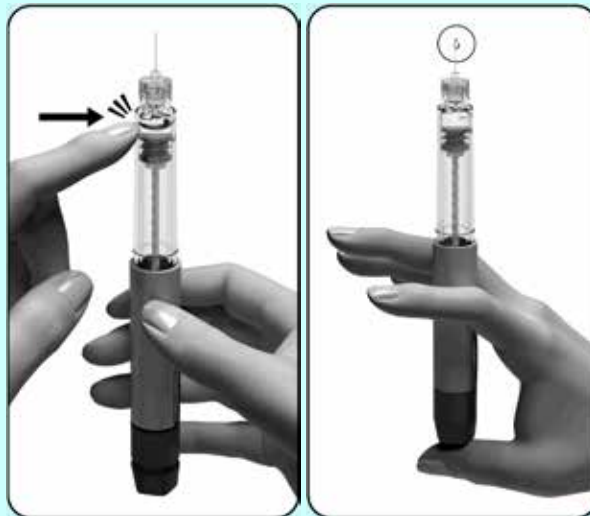

5. If you do not see any liquid, you may try a second time (you may do this a maximum of two times) starting from step 1 of section “If you do not see a tiny drop(s) of fluid at or near the tip” above.

4. Setting the dose to 250

- Gently turn the dose setting knob clockwise. The dose display will show a straight line and you have to keep turning until you can read the number ‘250’.
- Do not push or pull the dose setting button while you turn it.

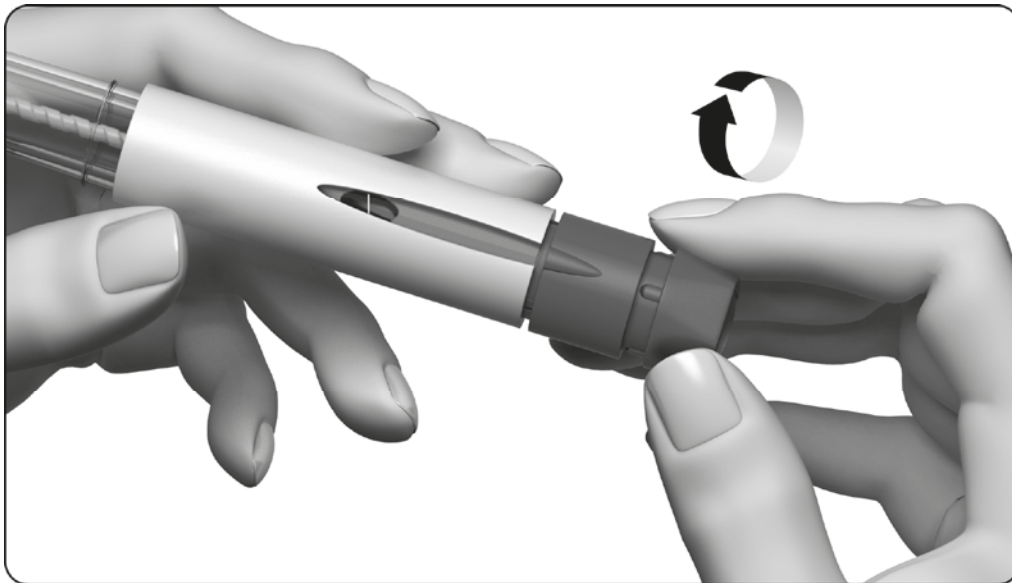

- The dose display should show '250', shown in the figure below.

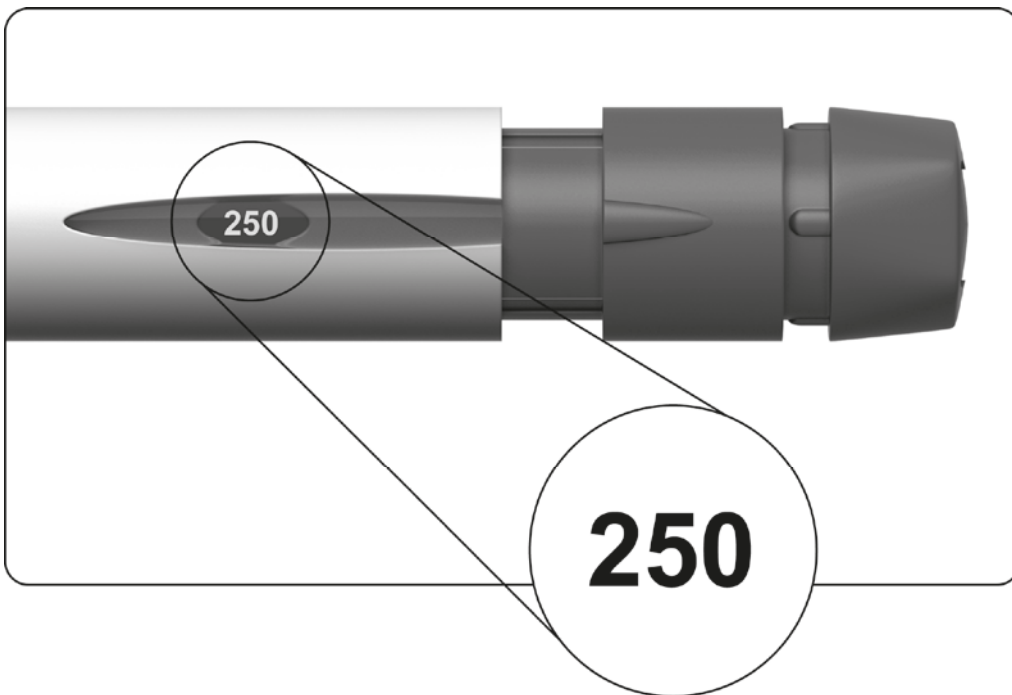

5. Injecting the dose

- 5.1 Choose the injection site in the area your doctor or nurse has told you to give the injection.
- 5.2 Clean the skin at the injection site by wiping with an alcohol swab.
- 5.3 Verify once more that the number in the **dose display reads '250'**. If it is not, you must adjust it (see step "4. Setting the dose to 250").

5.4 Inject the dose as you were trained to do by your doctor or nurse

- Slowly push the needle into the skin entirely (1).
- **Press the dose knob down as far as it will go** and hold it to complete the full injection.
- Hold the dose knob down for a minimum of 5 seconds to ensure you inject the full dose (2).
- **The dose number shown in the dose display will turn back to '0'. This shows that the complete dose was delivered.**
- After a minimum of 5 seconds, pull the needle out of the skin while keeping the dose setting knob pressed down (3).
- Release the dose setting knob.

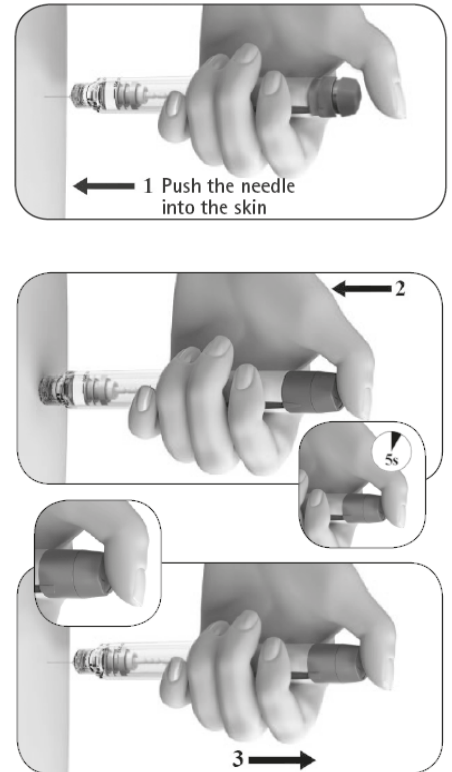

6. After the injection

6.1 Check that the dose display shows '0'

- This confirms that the dose has been fully delivered. **Do not attempt to inject a second time.**
- In case the dose display doesn't show '0', please contact your doctor or pharmacist.

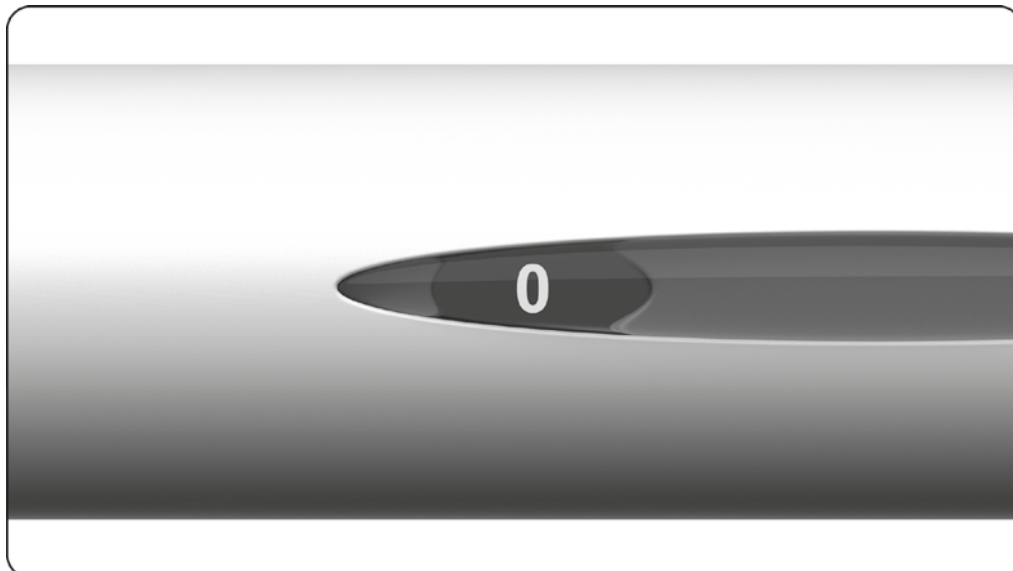

6.2 Removing the needle after injection

- Hold the pre-filled pen firmly by the reservoir holder.
- Carefully put the outer needle cap onto the needle.

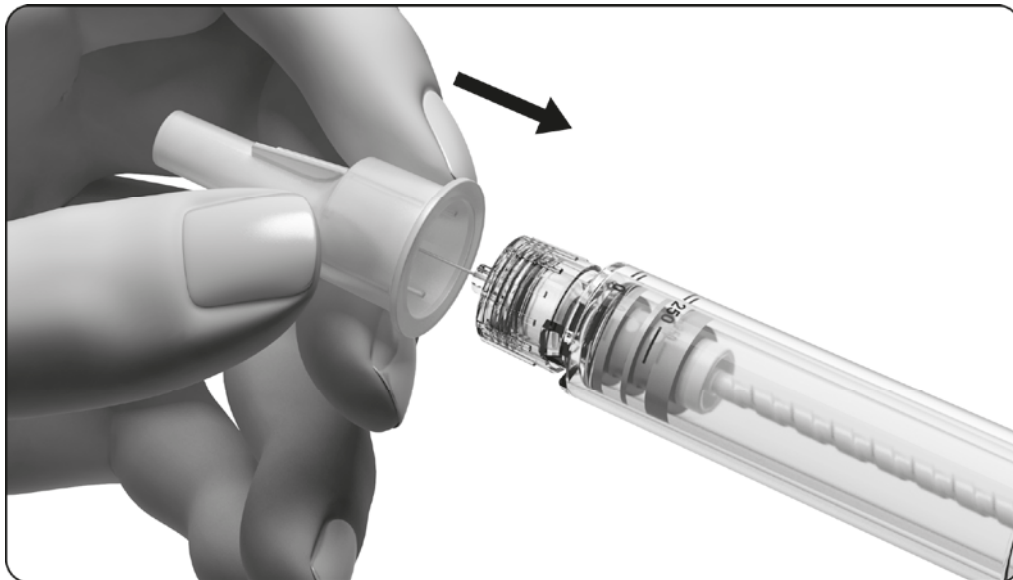

- Then grip the outer needle cap and unscrew the needle.

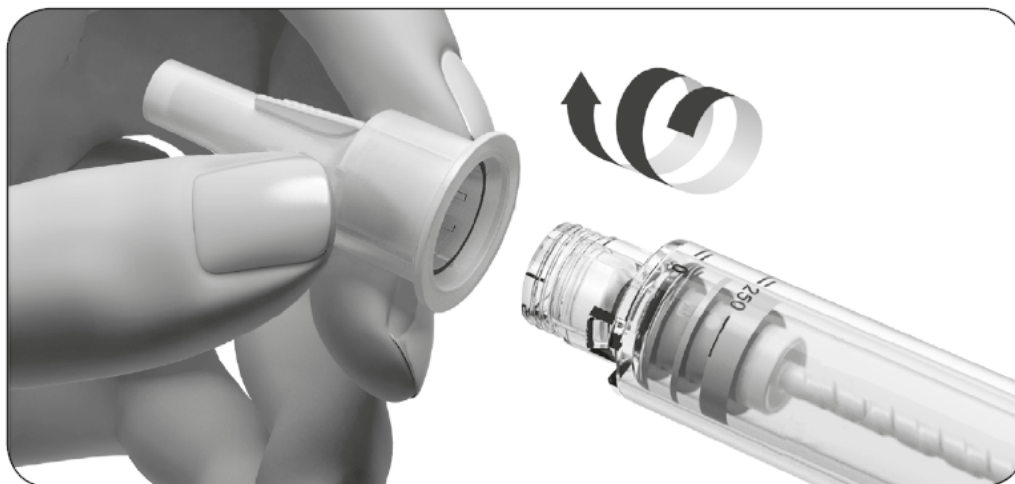

- Be careful not to prick yourself with the needle.
- Now put the pen cap back onto the pen.

6.3 Disposal

- Use the needle and pen only once.
- Once you have finished your injection, dispose of the used needle safely.
- Discard the pen. It is best to put it back into its original package.
- When the pen is empty, ask your pharmacist how to dispose of it.



Warning: Do not throw away any medicine via wastewater or household waste.

These instructions for use were last revised in: